

Indicador digital con entrada para:
 PROCESO ($\pm 20\text{mA}$, $\pm 10\text{V}$ y $\pm 200\text{V}$ -dinamo tacométrica-)
 TEMPERATURA (Termopar J, K, T y N, RTD's Pt100 y Pt1000)
 POTENCIÓMETRO de 100 Ω a 100k Ω
 RESISTENCIA (Escalas 1k Ω , 10k Ω y 50k Ω)



Indicateur digitale pour signaux d'entrée:
 PROCESS ($\pm 20\text{mA}$, $\pm 10\text{V}$ et $\pm 200\text{V}$ -dynamo tachymétrique-)
 TEMPÉRATURE (Thermocouple J, K, T et N, RTD's Pt100 et Pt1000)
 POTENTIOMÈTRE 100 Ω à 100k Ω
 RÉSISTANCE (Plages 1k Ω , 10k Ω et 50.00k Ω)

Digital indicator for input signal:
 PROCESS ($\pm 20\text{mA}$, $\pm 10\text{V}$, $\pm 200\text{V}$ -tachometric dynamo-)
 TEMPERATURE (Thermocouple J, K, T and N, RTD's Pt100 and Pt1000)
 POTENTIOMETER from 100 Ω to 100k Ω
 RESISTANCE (Ranges 1k Ω , 10k Ω and 50k Ω)

Digitalanzeige für Eingangssignal:
 PROZESS ($\pm 20\text{mA}$, $\pm 10\text{V}$, $\pm 200\text{V}$ -tachymetrischer Dynamo-)
 TEMPERATUR (Thermoelemente J, K, T und N, WTH Pt100 und Pt1000)
 POTENTIOMETER von 100 Ω bis 100k Ω
 WIDERSTAND (Bereiche 1k Ω , 10k Ω und 50k Ω)



GUIA RÁPIDA DE INSTALACIÓN GUIDE RAPIDE D'INSTALLATION QUICK INSTALLATION GUIDE SCHNELL-INSTALLIERUNGSANLEITUNG

Proceso. Process. Process. Prozess.

Rango Plage Range Bereich	$\pm 20\text{mA}$	$\pm 10\text{V}$	$\pm 200\text{V}$
Impedancia de entrada Impédance d'entrée Input impedance Eingangsimpedanz	20.5 Ω +PTC 5 Ω	1M Ω	1M Ω
Precisión Précision Accuracy Genauigkeit	$\pm(0.1\% \text{ rdg} + 15\mu\text{A})$	$\pm(0.1\% \text{ rdg} + 6\text{mV})$	$\pm(0.1\% \text{ rdg} + 0.1\text{V})$
Excitación Excitation Excitation Speisung	24V $\pm 3\text{V}$ @ 30mA		

Potenciómetro. Potentiomètre. Potentiometer. Potentiometer.

Rango Plage Range Bereich	100 Ω - 100k Ω
Máxima corriente de medida Courant maximale de mesure Maximum measurement current Maximale Strommessung	<0.4mA
Precisión Précision Accuracy Genauigkeit	$\pm 0.1\% \text{ rdg} + 0.05\% \text{ F.S.}$

Resistencia. Résistance. Resistance. Widerstand.

Rango Plage Range Bereich	999.9 Ω	9999 Ω	50k Ω
Máxima corriente de medida Courant maximale de mesure Maximum measurement current Maximale Strommessung	750 μA	100 μA	<0.4mA
Precisión Précision Accuracy Genauigkeit	$\pm(0.1\% \text{ rdg} + 0.7\Omega)$	$\pm(0.1\% \text{ rdg} + 6\Omega)$	$\pm(0.1\% \text{ rdg} + 35\Omega)$

Temperatura. Température. Temperature. Temperatur.

RTD (IEC 60751)	Pt100		Pt1000	
Rango Plage Range Bereich	-150 $^{\circ}\text{C}$ 800 $^{\circ}\text{C}$			
Máxima corriente de medida Courant maximale de mesure Maximum measurement current Maximale Strommessung	1mA		100 μA	
Máxima resistencia por hilo Résistance maximale par fil Maximum resistance per wire Maximale Widerstand pro Leiter	40 Ω		-	
Coefficiente α Coefficient α Coefficient α Koeffizient α	0.00385			
Precisión Précision Accuracy Genauigkeit	$\pm(0.15\% \text{ rdg} + 0.5^{\circ}\text{C})$			
TC (IEC 60584-1)	J	K	T	N
Rango Plage Range Bereich	-150 $^{\circ}\text{C}$ +1100 $^{\circ}\text{C}$	-150 $^{\circ}\text{C}$ +1200 $^{\circ}\text{C}$	-150 $^{\circ}\text{C}$ 400 $^{\circ}\text{C}$	-150 $^{\circ}\text{C}$ 1300 $^{\circ}\text{C}$
Compensación unión fría Compensation jonction froide Cold junction compensation Vergleichstellungskompensation	-10 $^{\circ}\text{C}$ - 60 $^{\circ}\text{C}$			
Precisión Précision Accuracy Genauigkeit	$\pm(0.1\% \text{ rdg} + 0.6^{\circ}\text{C})$	$\pm(0.2\% \text{ rdg} + 0.8^{\circ}\text{C})$	$\pm(0.1\% \text{ rdg} + 0.6^{\circ}\text{C})$	$\pm(0.1\% \text{ rdg} + 0.6^{\circ}\text{C})$

Conformidad CE. Conformité CE. CE Conformity. CE-Konformität.

Directivas Directives Directives Richtlinien	EMC 2004/108/EC	LVD 2006/95/EC
Normas Normes Standards Normen	EN 61326-1	EN 61010-1



Para una información más completa, por favor consulte el manual de instrucciones en nuestra web <http://www.ditel.es/jrp.htm>
 Pour plus d'informations veuillez consulter le manuel dans notre site web <http://www.ditel.es/fjrp.htm>
 For complete instructions please refer to the user manual in our website <http://www.ditel.es/ejrp.htm>
 Für weitere Informationen, konsultieren Sie bitte die Bedienungsanleitung auf unserem web <http://www.ditel.es/djrp.htm>

Según la Directiva 2002/96/CE, no puede deshacerse de este aparato como un residuo urbano normal. Puede devolverlo, sin coste alguno, al lugar donde fue adquirido para que de esta forma se proceda a su tratamiento y reciclado controlados.
 Selon la Directive 2002/96/CE, l'utilisateur ne peut se défaire de cet appareil comme d'un résidu urbain courant. Vous pouvez le restituer, sans aucun coût, au lieu où il a été acquis afin qu'il soit procédé à son traitement et recyclage contrôlés.
 According to 2002/96/CE Directive, You cannot dispose of it at the end of its lifetime as unsorted municipal waste. You can give it back, without any cost, to the place where it was acquired to proceed to its controlled treatment and recycling.
 Gemäß der Richtlinie 2002/96/EG darf dieses Elektronikgerät nicht über den herkömmlichen Haushaltsmüllkreislauf entsorgt werden. Sie kann das Gerät kostenlos an die Stelle von der es erworben wurde, für die kontrollierte Bearbeitung und Wiederverwertung zurückgeben.

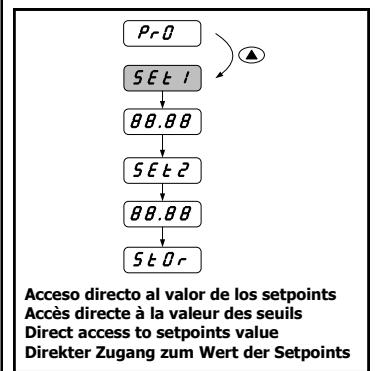
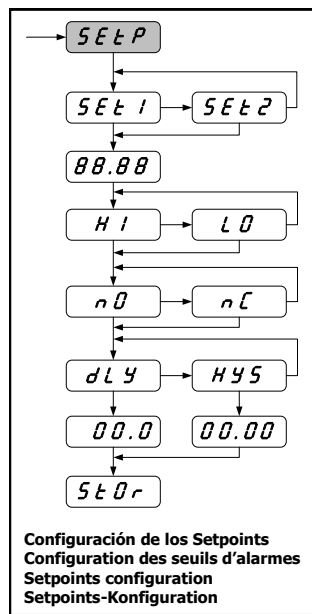
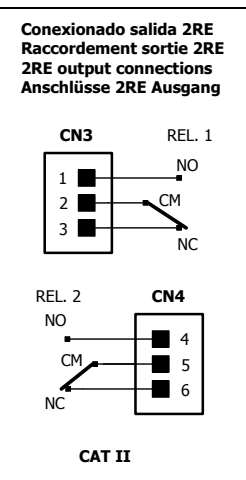
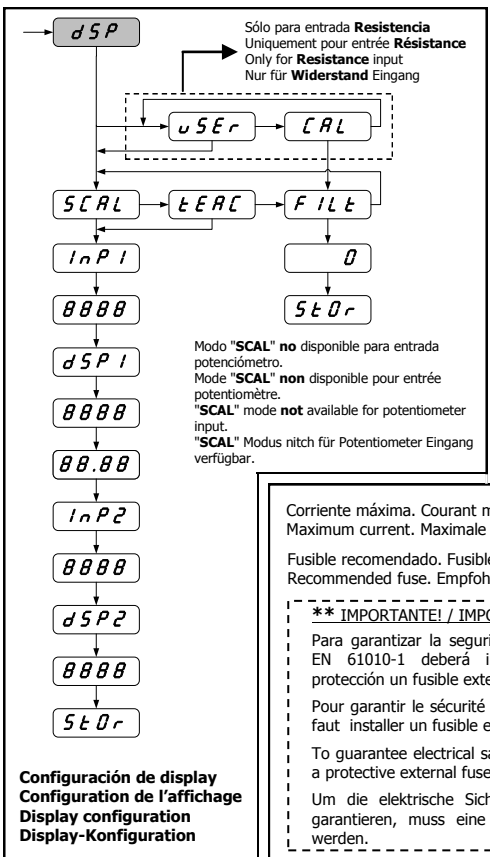
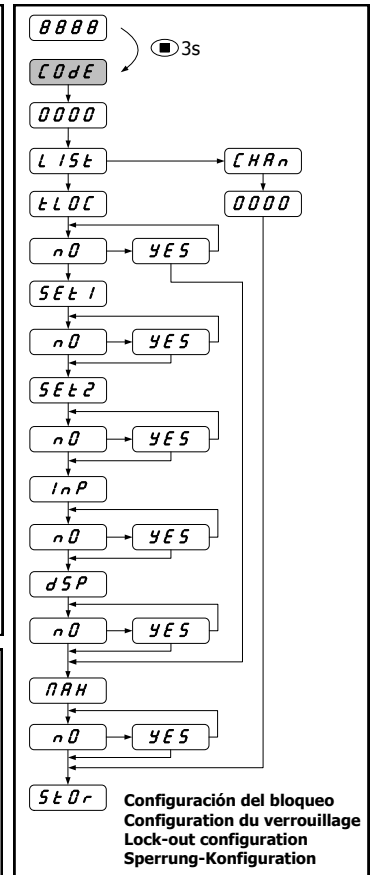
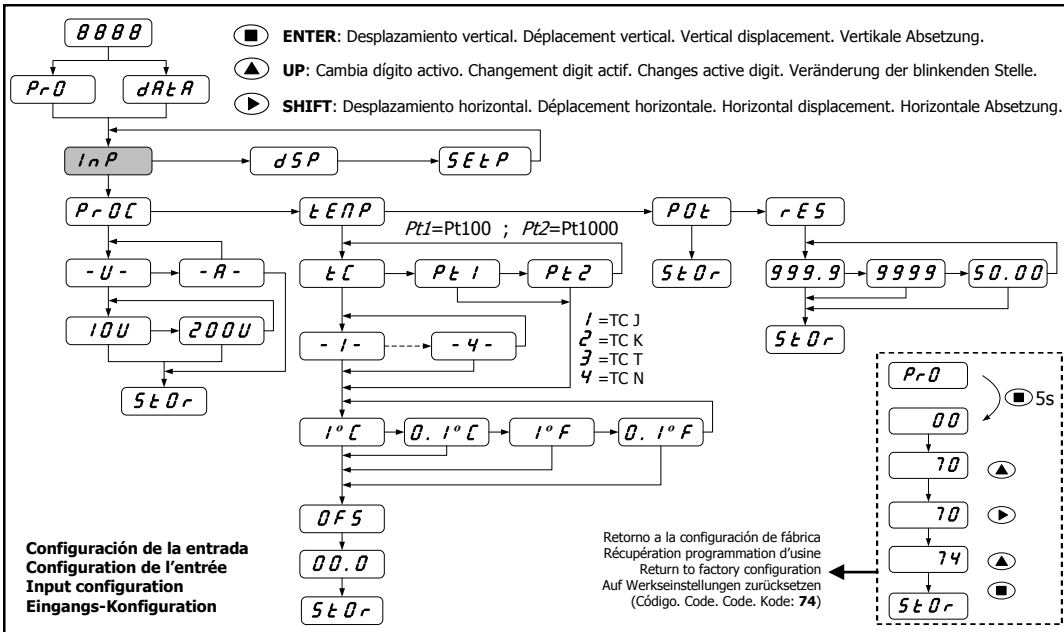

Corriente máxima. Courant maximal.
 Maximum current. Maximale Strom. **8A**
 (250V AC/24V DC)

Fusible recomendado. Fusible recommandé.
 Recommended fuse. Empfohlene Sicherung. **8A**

**** IMPORTANTE! / IMPORTANT! / WICHTIG!**

Para garantizar la seguridad eléctrica de acuerdo con EN 61010-1 deberá instalarse como medida de protección un fusible externo.
 Pour garantir la sécurité électrique selon EN 61010-1 il faut installer un fusible externe de protection.
 To guarantee electrical safety according to EN 61010-1 a protective external fuse must be installed.
 Um die elektrische Sicherheit nach EN 61010-1 zu garantieren, muss eine externe Sicherung installiert werden.

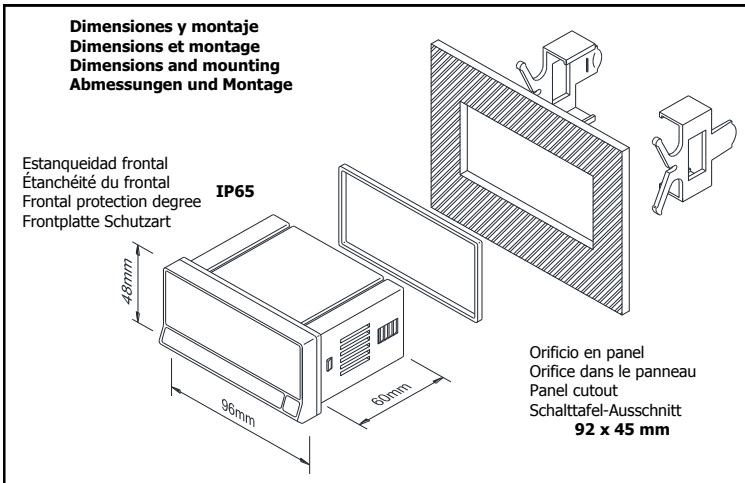
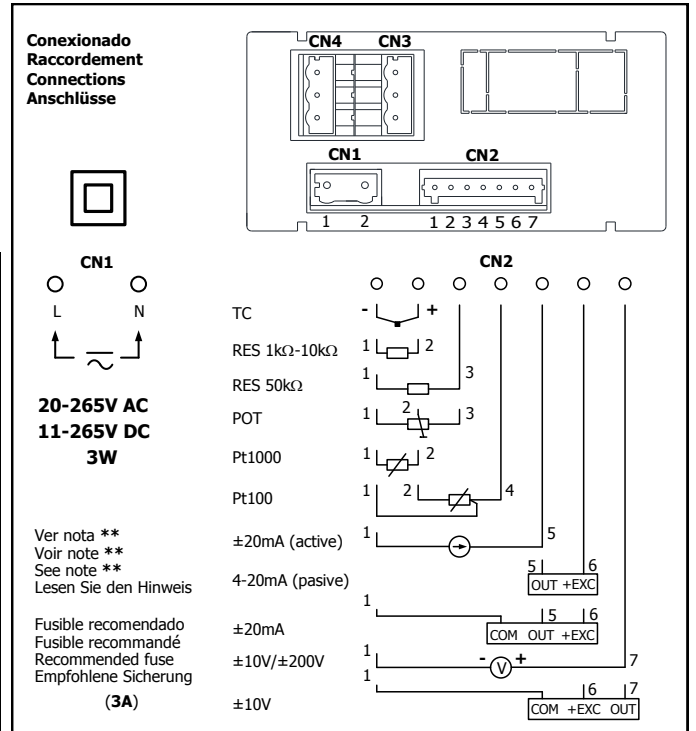

DISEÑOS Y TECNOLOGÍA, S.A.
 Xarol, 8-C P.I. Les Guixeres
 08915 Badalona (Barcelona) - Spain

Tel. +34 933 394 758
 Fax +34 934 903 145
 Email: dtl@ditel.es ; web: www.ditel.es